

Extreme Cantilever Deck

For 3" Diameter Leading Edge Bar
(pools narrower than 22')

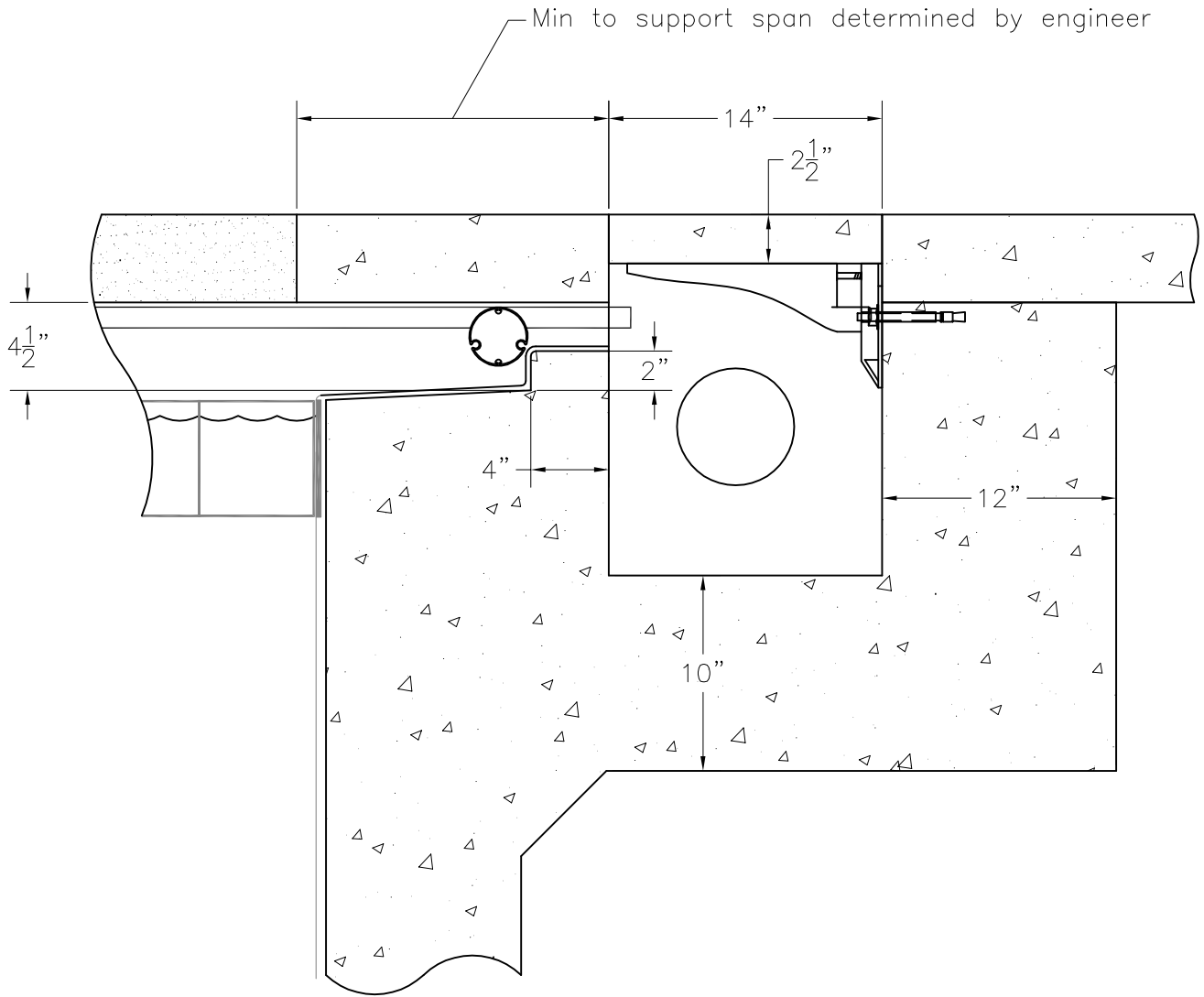

Gunite Detail

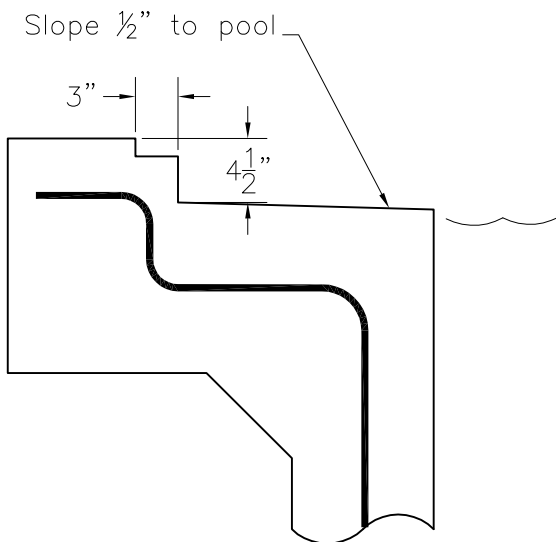

Forming Detail

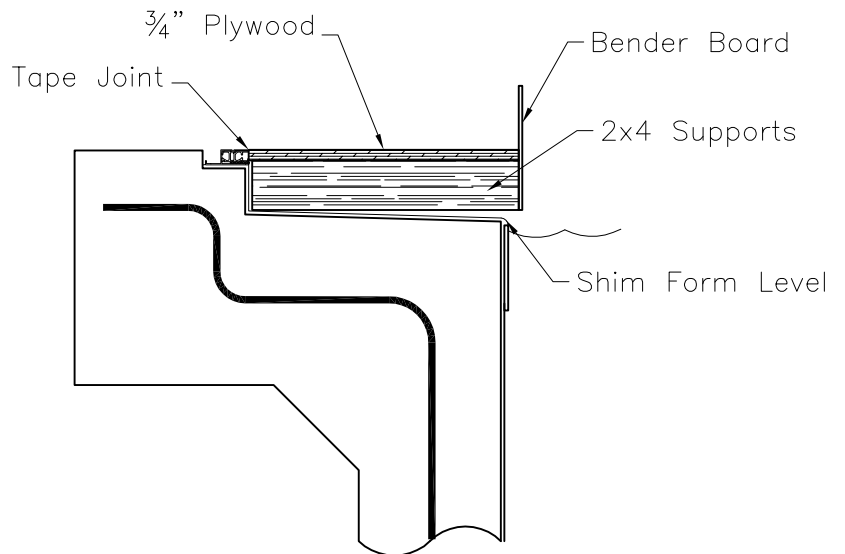

Extreme Cantilever Deck

For 3" Diameter Leading Edge Bar
(pools narrower than 22')

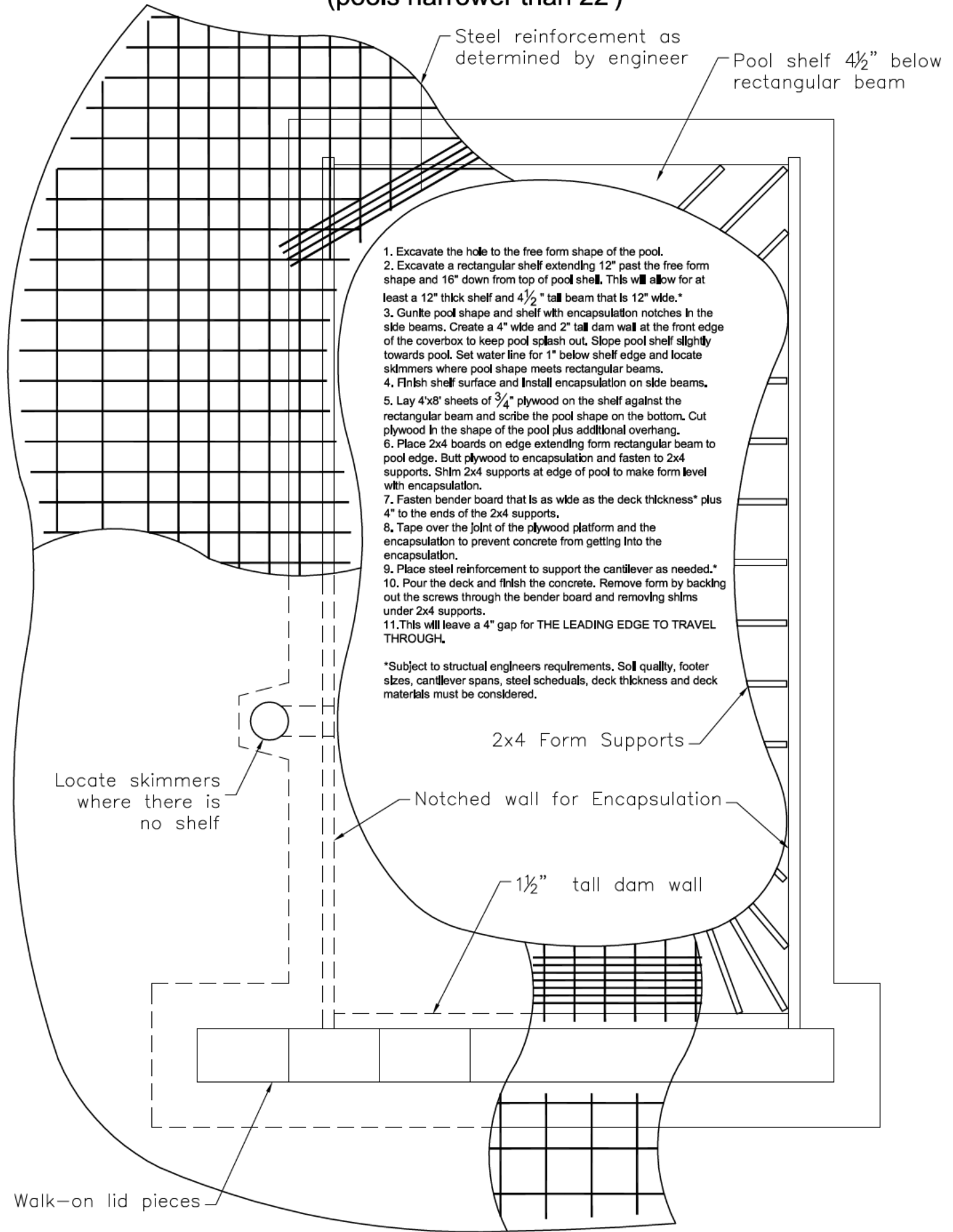

1. Excavate the hole to the free form shape of the pool.
2. Excavate a rectangular shelf extending 12" past the free form shape and 16" down from top of pool shell. This will allow for at least a 12" thick shelf and 4 1/2" tall beam that is 12" wide.*
3. Gunite pool shape and shelf with encapsulation notches in the side beams. Create a 4" wide and 2" tall dam wall at the front edge of the coverbox to keep pool splash out. Slope pool shelf slightly towards pool. Set water line for 1" below shelf edge and locate skimmers where pool shape meets rectangular beams.
4. Finish shelf surface and install encapsulation on side beams.
5. Lay 4'x8' sheets of 3/4" plywood on the shelf against the rectangular beam and scribe the pool shape on the bottom. Cut plywood in the shape of the pool plus additional overhang.
6. Place 2x4 boards on edge extending from rectangular beam to pool edge. Butt plywood to encapsulation and fasten to 2x4 supports. Shim 2x4 supports at edge of pool to make form level with encapsulation.
7. Fasten bender board that is as wide as the deck thickness* plus 4" to the ends of the 2x4 supports.
8. Tape over the joint of the plywood platform and the encapsulation to prevent concrete from getting into the encapsulation.
9. Place steel reinforcement to support the cantilever as needed.*
10. Pour the deck and finish the concrete. Remove form by backing out the screws through the bender board and removing shims under 2x4 supports.
11. This will leave a 4" gap for THE LEADING EDGE TO TRAVEL THROUGH.

*Subject to structural engineers requirements. Soil quality, footer sizes, cantilever spans, steel schedules, deck thickness and deck materials must be considered.